

Mounting instructions

Cassettes for jointless floors



Cassettes for jointless floors

Mounting instructions

Inhaltsverzeichnis

1	About these instructions.	5
1.1	Target group	5
1.2	Relevance of these instructions.	5
1.3	Types of warning information	5
1.4	Basic standards and regulations	5
1.5	Applicable documents	5
2	Intended use	6
3	Safety	6
3.1	General safety information	6
3.2	Personal protective equipment	6
4	Necessary tools.	6
5	Product overview	7
5.1	Product description	7
5.2	Accessories	8
5.3	Installation principle	9
5.3.1	Screed types	9
6	Mounting the cassette	9
6.1	Preparations for mounting	9
6.2	Applying the cassette	13
6.3	Preparing for screed laying	16
6.4	Laying the supporting screed	19
6.5	Applying the design screed/Terrazzo covering (facing formwork).	19
6.6	Final work after screed laying	21
6.7	Inserting accessories	22
7	Dismantling the cassette.	22
8	Disposing of the cassette	22
9	Technical data.	23

1 About these instructions

1.1 Target group

These instructions are intended for the following target groups:

- Trained electrical specialists charged with mounting the cassette
- Electrical planners and engineers charged with the planning of under-floor systems
- Manufacturers of Terrazzo coverings and ground/polished design screed



Electrical work may only be carried out by specialist personnel with appropriate training.

1.2 Relevance of these instructions

These instructions are based on the standards valid at the time of compilation (October 2022).

Please read the instructions carefully before starting mounting. We will not accept any warranty claims for damage caused through non-observance of these instructions.

Any images are intended merely as examples. Mounting results may look different.

1.3 Types of warning information



CAUTION

Type of risk

Shows a risky situation. If the safety instruction is not observed, then medium or minor injuries may occur.

ATTENTION

Type of risk

Shows a damaging situation. If the safety instruction is not observed, then damage to the product or the surroundings may occur.

Note!

Indicates important information or assistance.

1.4 Basic standards and regulations

The UZD/UGD55 system components and the height-adjustable cassettes fulfil the requirements of EN 50085-2-2 for electrical installations. The cover of the cassette is used as a protective cover during screed work and thus must only support normal weights of people.

1.5 Applicable documents

- For the declaration of conformity, see www.obo-bettermann.com

2 Intended use

The design screed solutions are used for the seamless installation of cassettes in combination with underfloor accessory sockets in ground screed and Terrazzo floors in dry rooms, with dry or wet-care floors in interior areas.

The cassettes offer installation space for up to twelve sockets in conjunction with electrical installation or numerous data and multimedia connections.

The system is not intended for other purposes, particularly not for access to water, wastewater or gas pipelines, or those of other liquids.

3 Safety

3.1 General safety information

Observe the following general safety information:

- Contact with electrical current can lead to an electric shock
- Risk of cutting from plate edges

3.2 Personal protective equipment

List of personal protective equipment to be used:



Use hand protection

4 Necessary tools

List of required tools:

- Tools for fastening (hammer drill, hammer, screwdriver)
- Levelling device (e.g. laser)
- Cutter (knife)
- Screwdriver
- Crosshead screwdriver PZ2
- Spirit level
- AF5 Allen key

5 Product overview

5.1 Product description

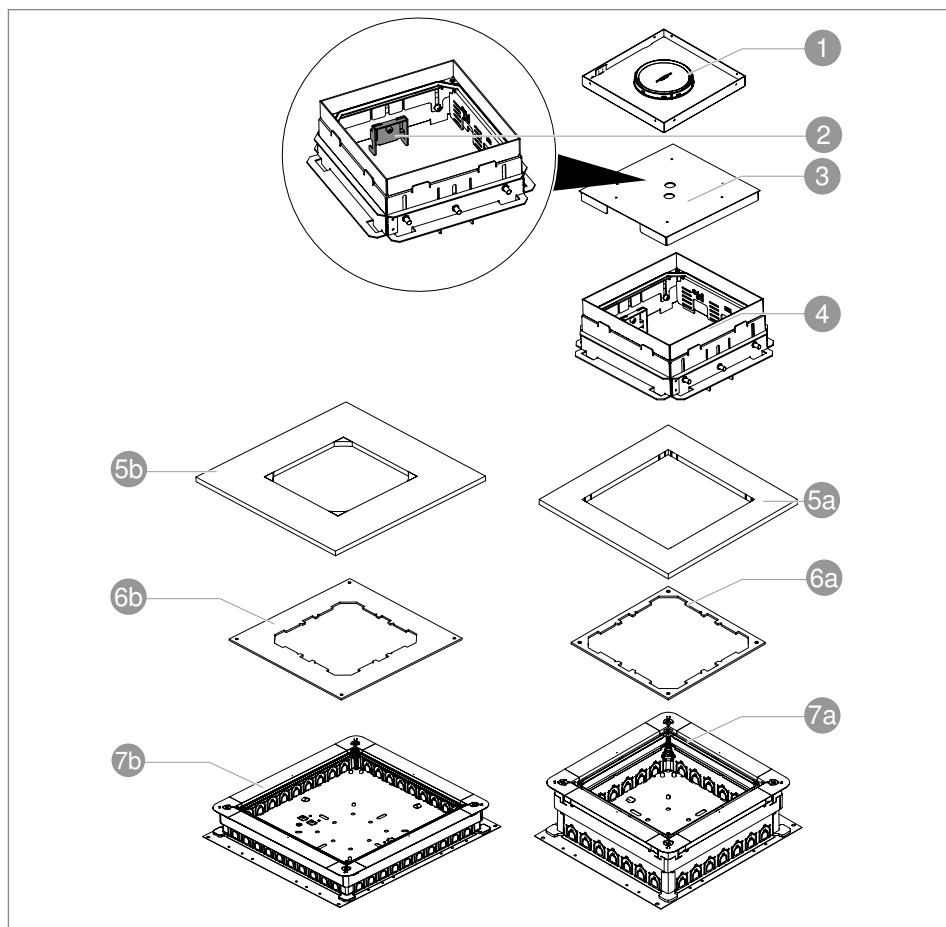
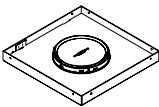
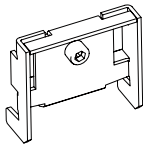
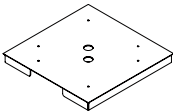
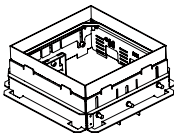
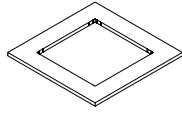
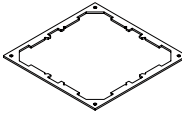
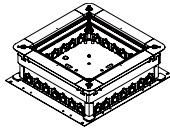

Fig. 1: Product description

No.	Product name	Figure	Function
1	Cassette cover		Cassette cover to close off the cassette after mounting.
2	Holding claws		Holding claws to fix the cassette to the UZD/UGD55 underfloor accessory socket. The removal of the holding claws decouples the cassette.
3	Screed protection cover		The screed protection cover protects the interior of the underfloor accessory socket against the ingress of screed during mounting.
4	Cassette		Cassette for surface-flush installation with integrated height-adjustment function.

5	ISO apron		ISO apron for insulation/separation of the UZD/UGD55 underfloor accessory and the cassette. For nominal size 250 and 350 (UZD/UGD55) available.
6	Mounting frame		The mounting frame creates the fastening points for the holding claws and is screwed to the UZD/UGD55. For nominal size 250 and 350 (UZD/UGD55) available.
7	UZD/UGD55 underfloor accessory socket		UZD/UGD55 underfloor accessory socket with adjustable installation opening. The height of the underfloor accessory sockets can be adjusted and thus adapted to different floor heights. The UZD/UGD55 underfloor accessory socket is not contained in the scope of delivery and must be ordered separately. For nominal size 250 and 350 (UZD/UGD55) available.

The design screed solution is used for surface-flush, seamless installation of height-adjustable cassettes into the floor area. In doing so, the mounting frame is screwed to the UZD/UGD55 underfloor accessory socket and the cassette is placed on the mounting frame with the ISO apron.

This means that the non-reduced screed thickness above the underfloor accessory socket can be used. An aluminium protection cover, which closes the cassette flush, can be polished over with the screed layer.

The cassettes offer installation space for up to twelve sockets or numerous data and multimedia connections of the OBO Modul 45® series.

The side walls of the underfloor accessory sockets are pre-marked so openings for duct sections and installation pipes can be easily made at the construction site. The socket bodies are made from galvanised sheet steel with a zinc coating of 275 g/m² to EN 10327 DX51D+Z275-N-A-C.

5.2 Accessories

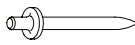
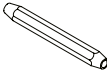
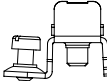
Designation	Figure	Function	Item no.
Quick height-adjustment aid		The quick release aid are required for toolless height adjustment.	7410160
OBO anchor		The OBO anchor fastens the UZD/UGD55 underfloor accessory socket to the substrate.	3105016
Flattener		Flattener for OBO anchors.	3031012
8AWR protective conductor connection bracket		For including the underfloor duct systems in the protective measure.	6288704

Tab. 1: Accessories

5.3 Installation principle

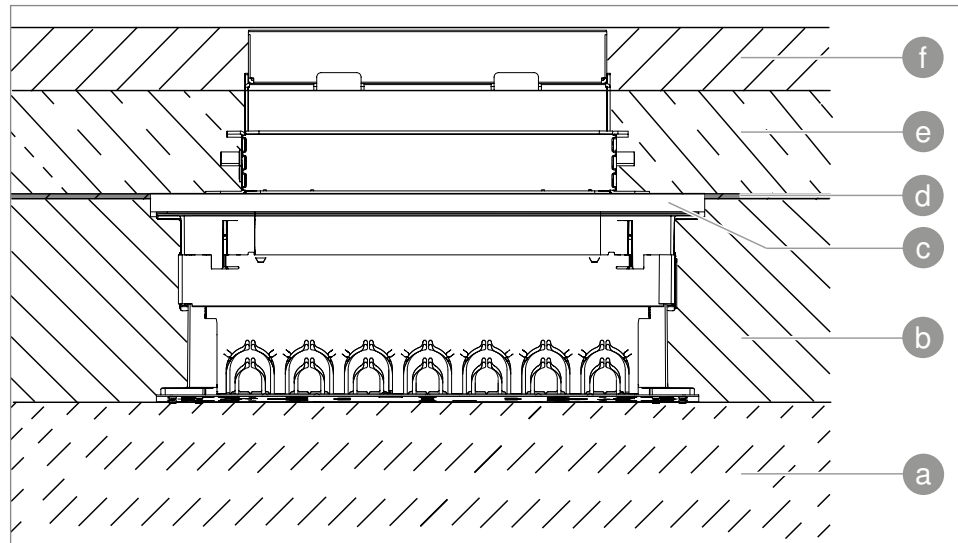

Fig. 2: Installation principle

Components in the floor cross-section (floor structure/height conditions may deviate depending on the floor planning):

- a** Raw floor
- b** Heat and footfall sound insulation
- c** ISO apron
- d** PE film
- e** Screed (floating support screed)
- f** Design screed, Terrazzo covering

5.3.1 Screed types

The screed-covered duct system is always suitable for installation in all screed types (according to DIN 18560). Some screed types (magnesia screed, poured asphalt) require appropriate preliminary work due to the properties of the screed materials.

6 Mounting the cassette

6.1 Preparations for mounting



CAUTION

Risk of electric shock!

The duct system must be connected in a manner that is fully conductive! The mounting of the screed-covered duct system takes place on the raw floor, as the required electrical connection would not otherwise be guaranteed.

ATTENTION

Risk of damage!

Product damage to the height-adjustment units!

During the construction phase, do not stand on the underfloor accessory sockets, as otherwise the duct system will not function. Damaged underfloor accessory sockets must be replaced.

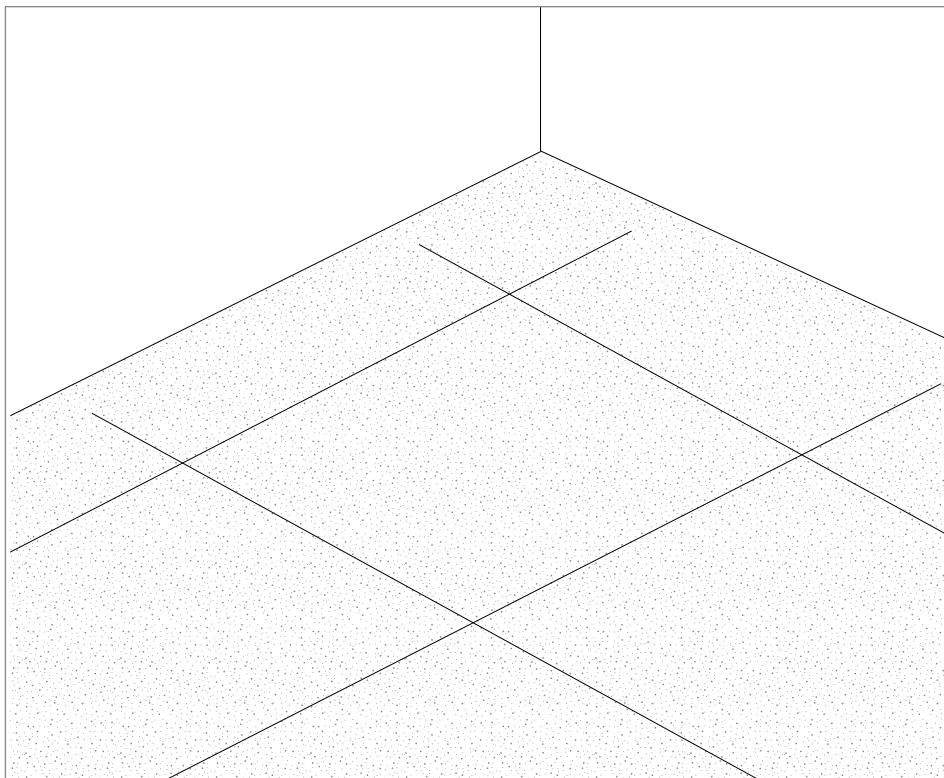

Fig. 3: Preparations for mounting

1. Create a clean, even raw floor as the basis.
2. Mark the planned cable routes and intersection points of the UZD/UGD55 underfloor accessory sockets **7** using a suitable tool (e.g. laser measurement device or chalk line) on the floor.

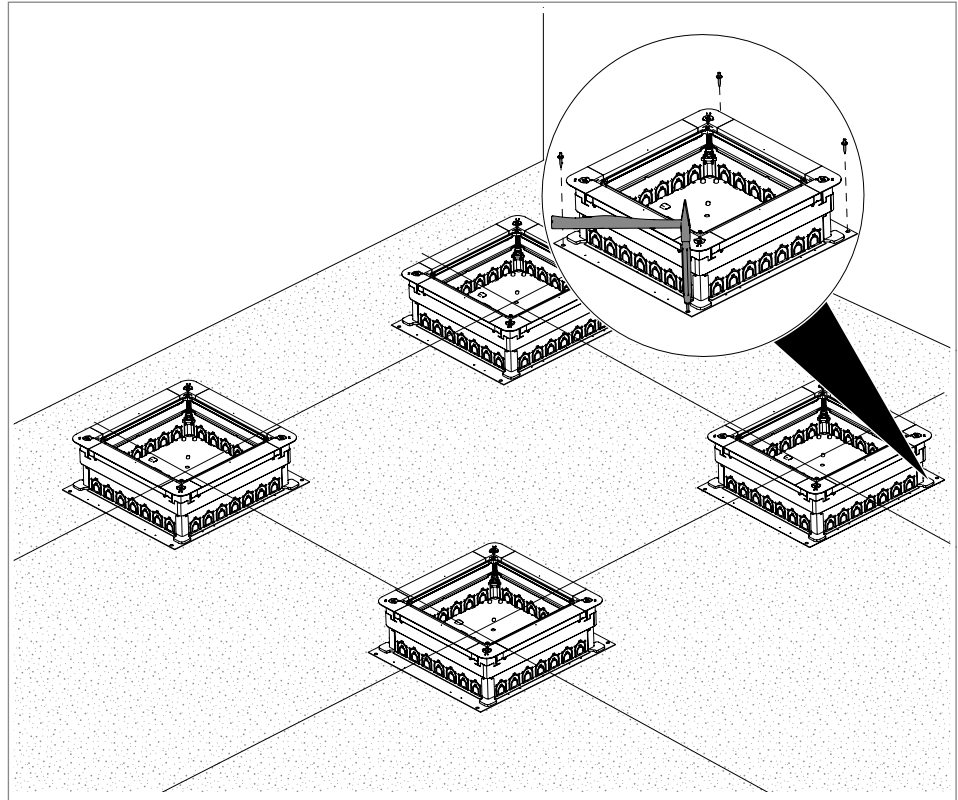

Fig. 4: Fastening the UZD/UGD55 underfloor accessory socket

3. Align the UZD/UGD55 underfloor accessory sockets ⑦ to the intersection points
4. Fasten the UZD/UGD55 underfloor accessory sockets ⑦ to the raw floor with suitable fastening material.

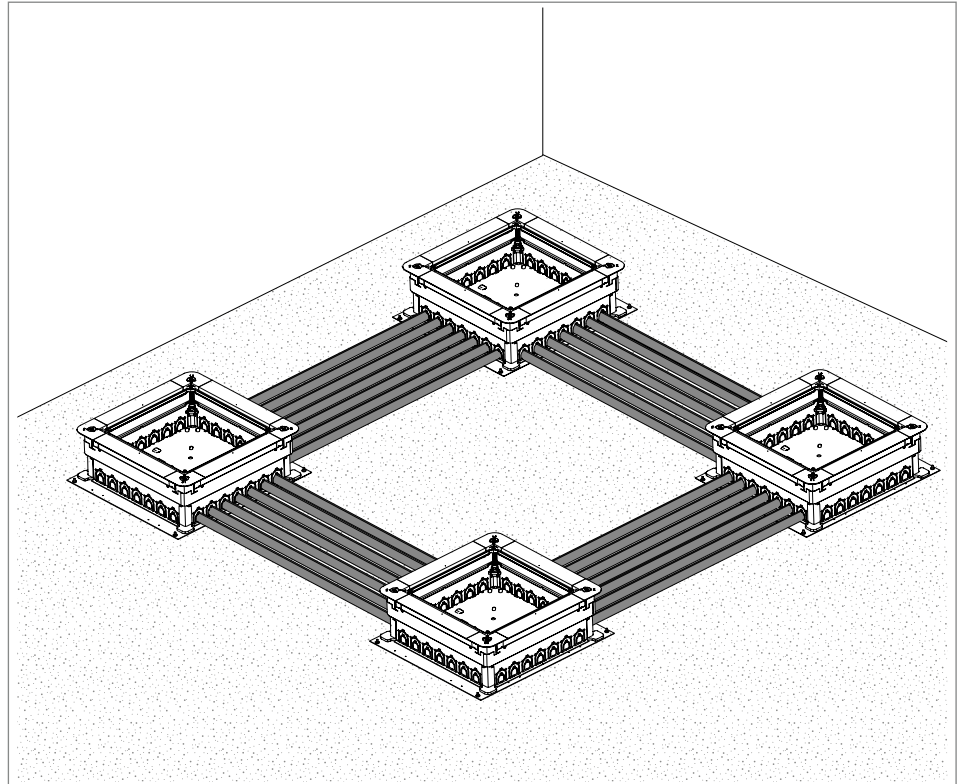

Fig. 5: Connecting the UZD/UGD55 underfloor accessory socket

5. Connect the UZD/UGD55 underfloor accessory sockets **7** with a suitable duct or trunking system or installation pipes.
6. Install cables.

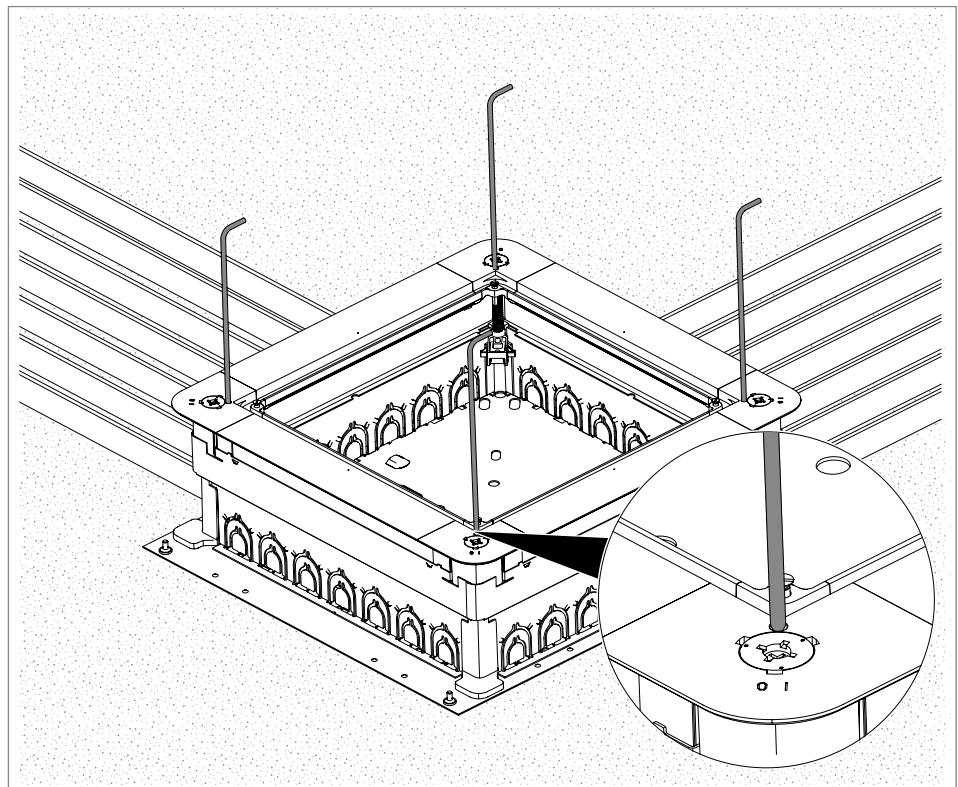

Fig. 6: Adjusting the height of the UZD/UGD55 underfloor accessory socket

7. Adjust the height of the UZD/UGD55 underfloor accessory sockets **7** using the 4 height-adjustment screws at the corners with the height-adjustment aid on the top edge of the insulation layer minus 12.5 mm (height of the ISO apron).
Alternatively, adjust the height using a PZ2 Pozidriv screwdriver. Minimum height: 70/55 mm (UZD/UGD55).

6.2 Applying the cassette

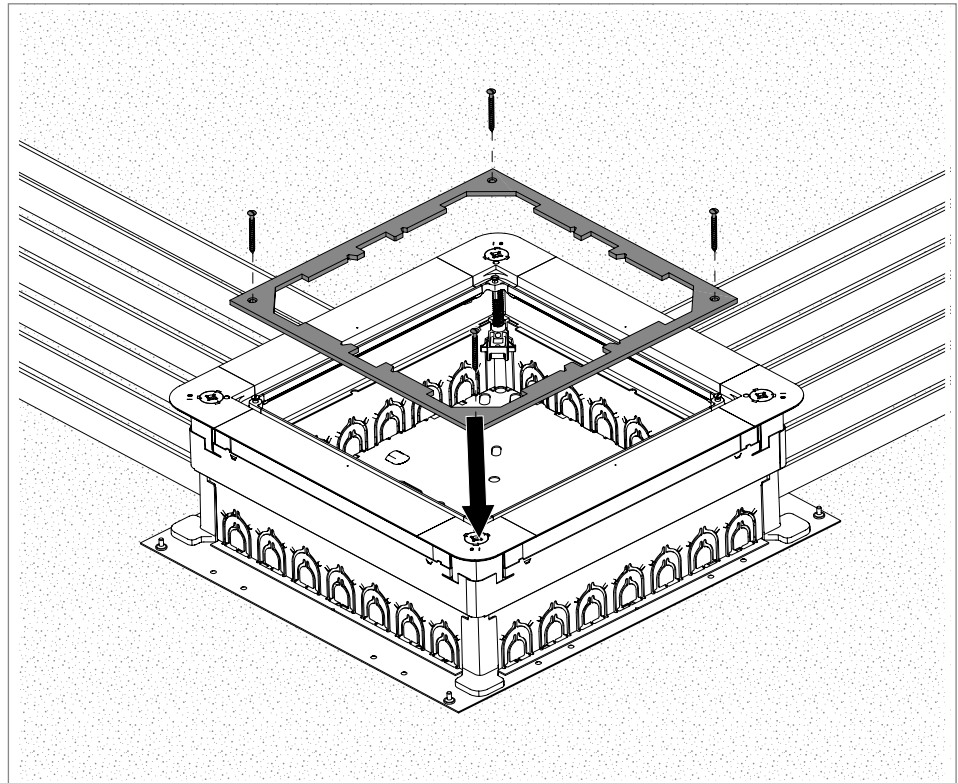

Fig. 7: Applying the mounting frame

1. Place the mounting frame **6** into the installation opening of the UZD/UGD55 underfloor accessory sockets **7** and screw it tight.

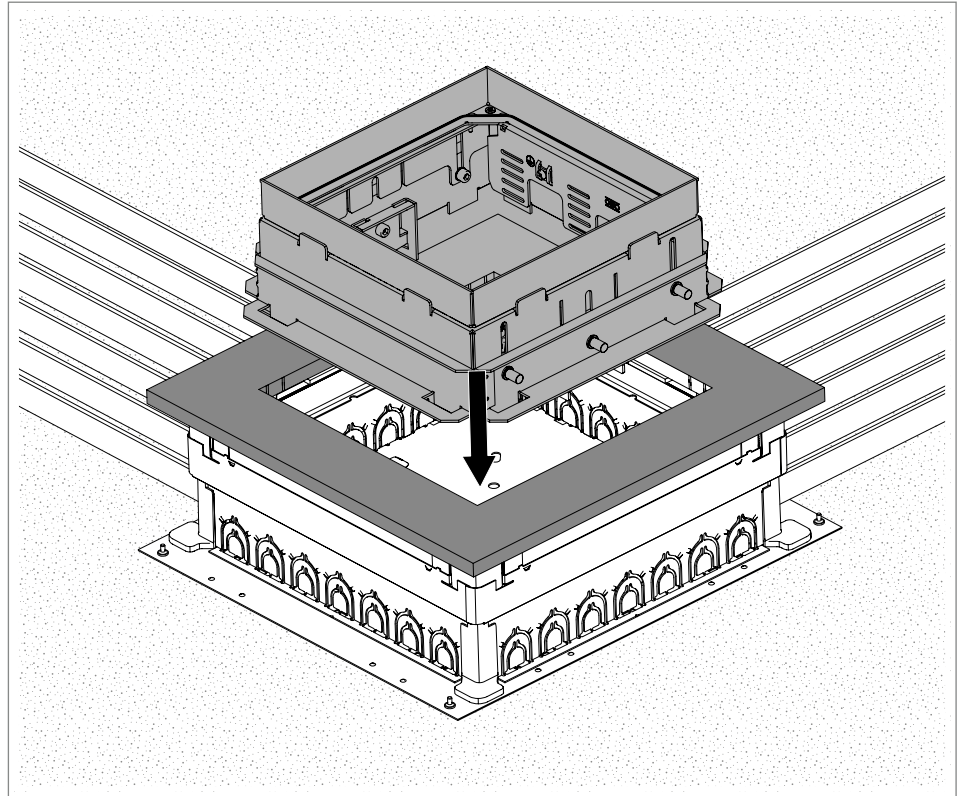

Fig. 8: Applying the ISO apron and cassette

Note! *Do not cut or shorten the ISO apron. The ISO apron must overlap the UZD/UGD55 underfloor accessory socket.*

Note! *Ensure that the height of the ISO apron is adjusted to the height of the top edge of the footfall sound insulation.*

2. Place the ISO apron **5** and Terrazzo cassette **4** on the UZD/UGD55 underfloor accessory sockets **7**.

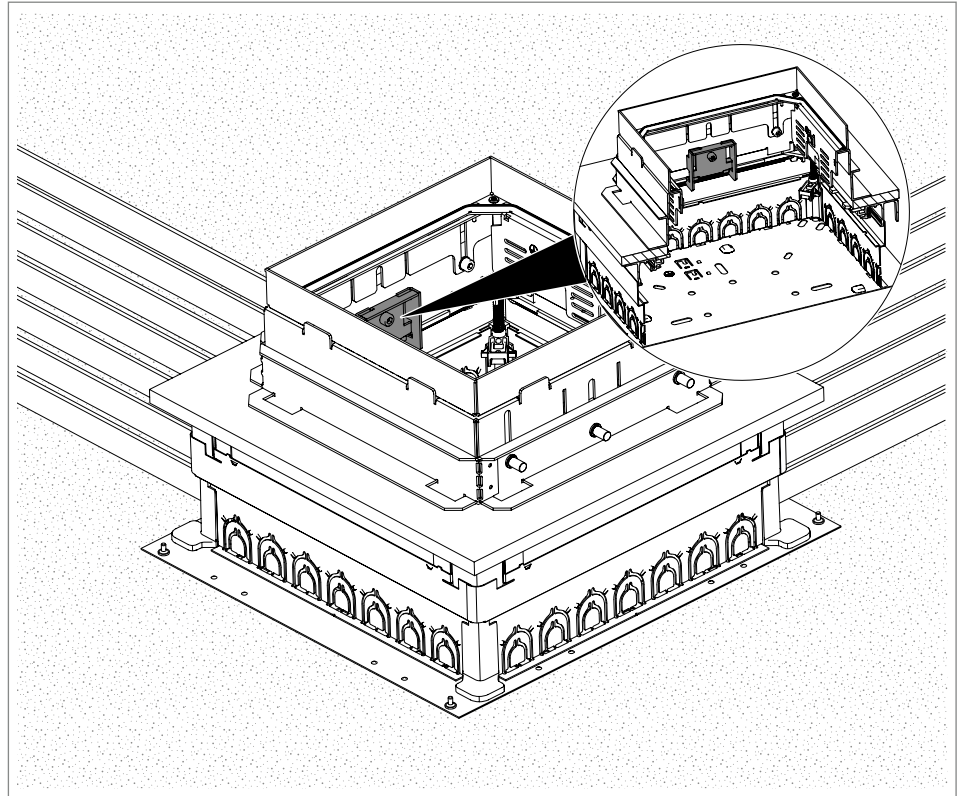

Fig. 9: Fastening the holding claws

3. Fasten the cassette **4** with 2 holding claws **2** in the centre of the mounting frame **6**.

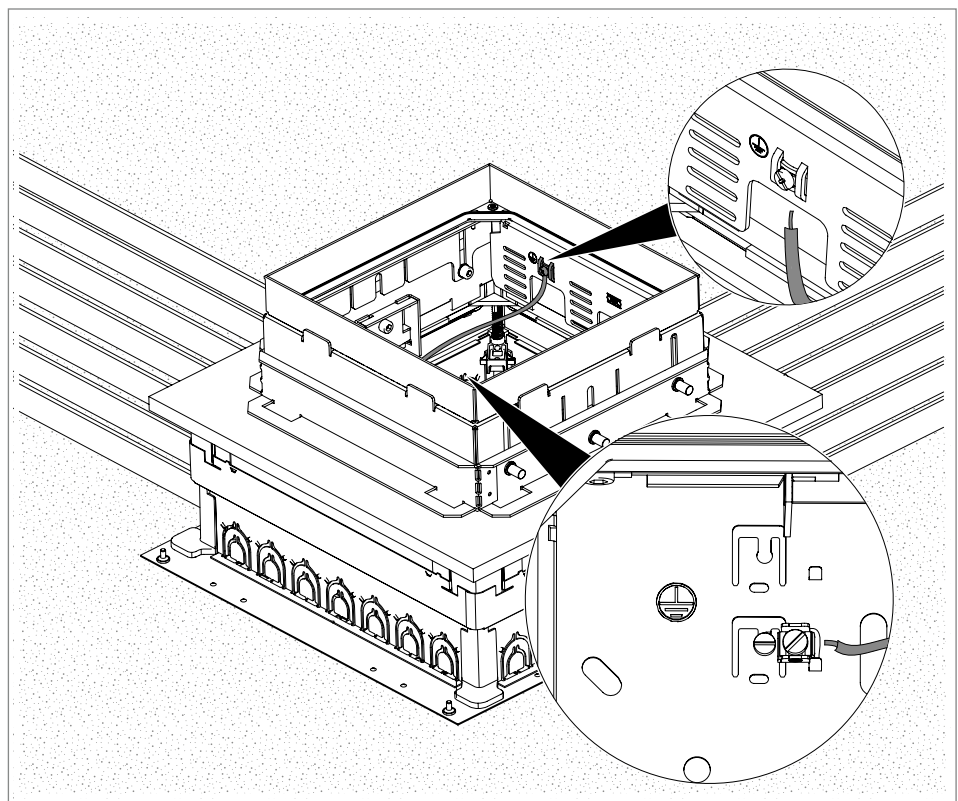

Fig. 10: Creating the equipotential bonding

4. Bend the earthing strap in the base of the UZD/UGD55 underfloor accessory sockets **7** and fasten the 8AWR protective conductor connection bracket.
5. Connect the earthing screw of the cassette **4** and UZD/UGD55 underfloor accessory socket **7** for the equipotential bonding.

6.3 Preparing for screed laying

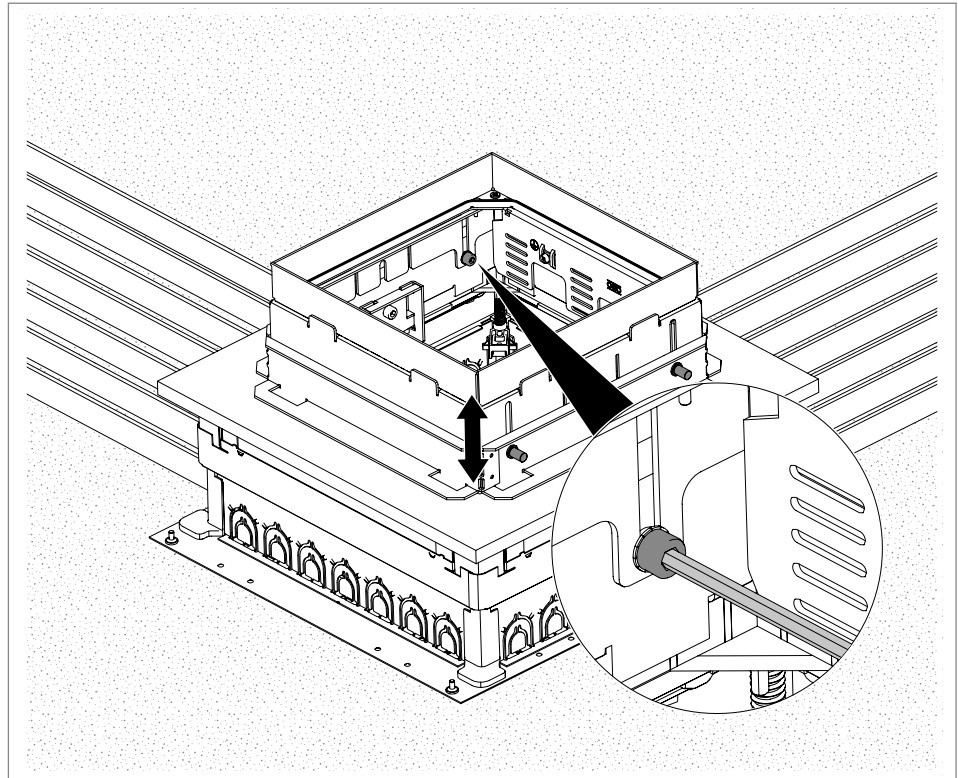

Fig. 11: Fine adjustment of the cassette

Note! *Adjustable height range (summary of screed and design screed thickness) is 68,5-108,5 mm.*

1. Adjust the height of the cassette **4** to the top edge of the visible screed using the 4 slots.
2. Tighten the screws (torque: 6 Nm).

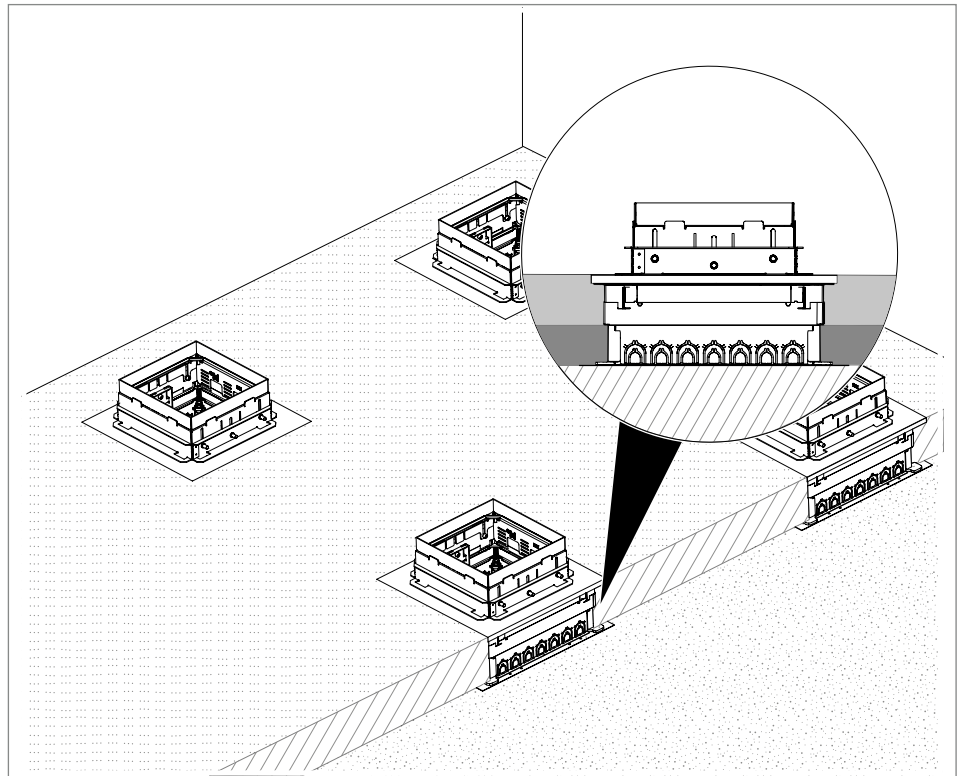

Fig. 12: Inserting the insulation/footfall sound insulation

3. Insert the heat and footfall sound insulation up to the height of the top edge of the ISO apron ⑤.
4. Cover the insulation layer, including ISO apron ⑤, with PE film.

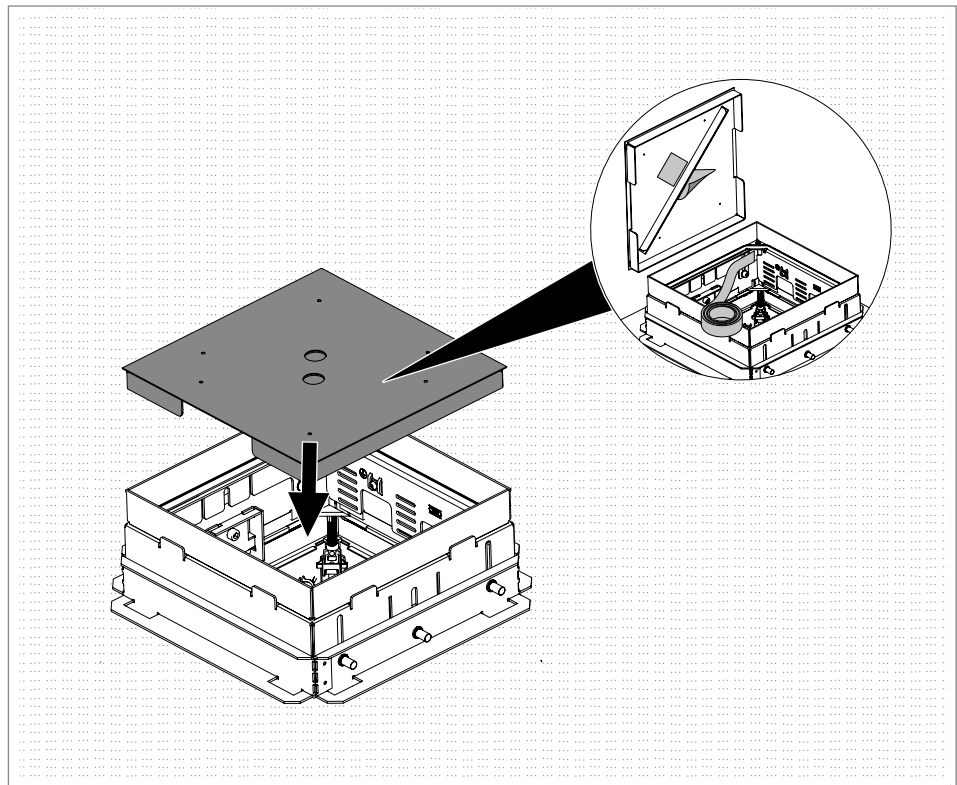

Fig. 13: Mask the cassette and screed protection cover

5. Insert the screed protection cover **3**.
6. Mask all the openings on the cassette from within **4** and the screed protection cover **3**, in order to prevent the screed compound from ingressing.

ATTENTION

Risk of damage!

Product damage on cassette/casing! The casing and the cassette must be grease-free before the treatment with reaction resin. Avoid damage to other components through cleaning agents.

7. Treat the cassette **4** with reaction resin from the outside, quartz and then leave to harden for 24 hours (coordination with the screed-laying company is required).

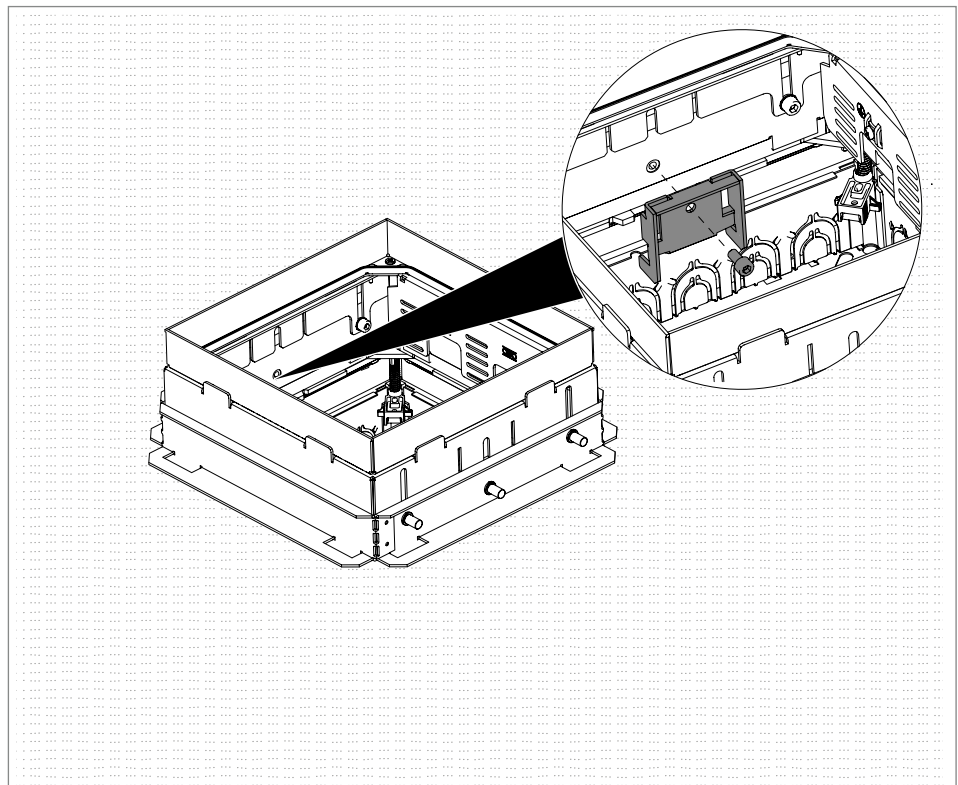

Fig. 14: Decoupling the cassette

Note! *Only decouple the cassette directly before applying the screed.*

8. Remove the screed protection cover **3**.
9. Decouple the cassette **4** by removing the holding claws **2** including screws.
10. Dispose of the holding claws **2**.
11. Insert the screed protection cover **3** again.
12. Check the installation height.

6.4 Laying the supporting screed

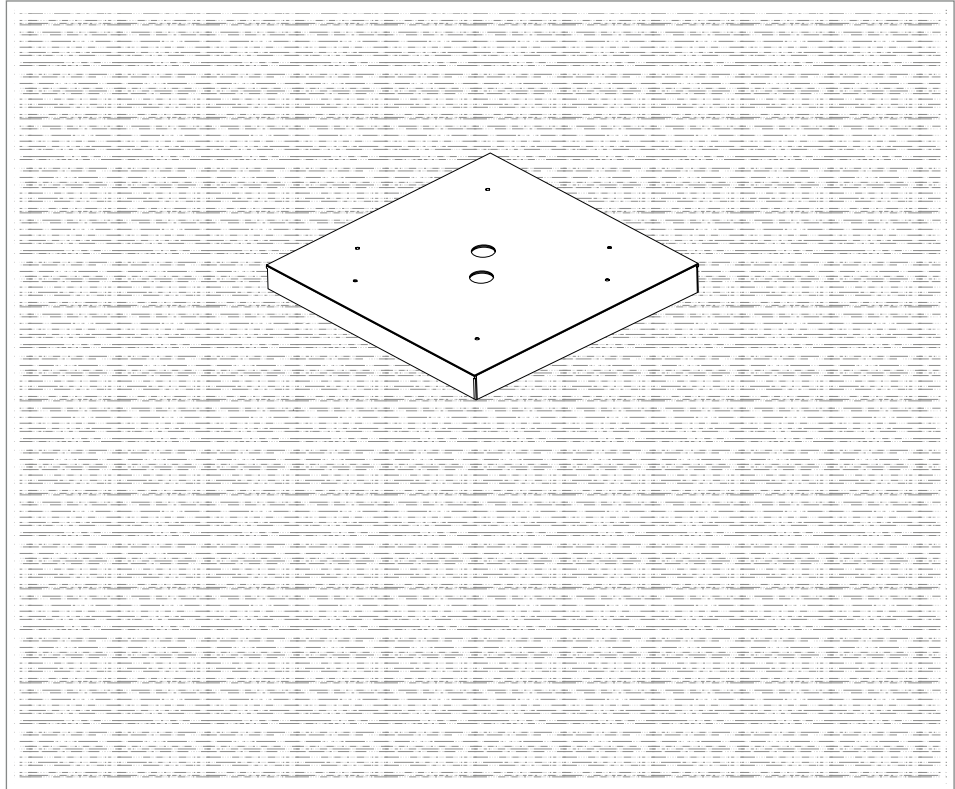

Fig. 15: Laying the screed

1. Coat the quartzed external sides of the cassette ⁴ up to the top edge of the support screed with a reaction resin bonding course.
2. Apply the floating support screed up to the bottom edge of the design screed.
3. Work the floating support screed up to the cassette ⁴.
4. Let the supporting screed harden.

6.5 Applying the design screed/Terrazzo covering (facing formwork)

ATTENTION

Risk of damage!

Product damage to the cassette!

During laying, the screed must be properly compacted, particularly around the cassette, so that there is a good connection between the screed and the cassette and crack formation is avoided.

ATTENTION

Risk of damage!

Product damage to the cassette!

Maintain a distance to the cassettes when polishing the screed with large machines, as the cassette frame could otherwise be destroyed by the grinding blades. In this area, polishing should take place separately with smaller hand-held machines.

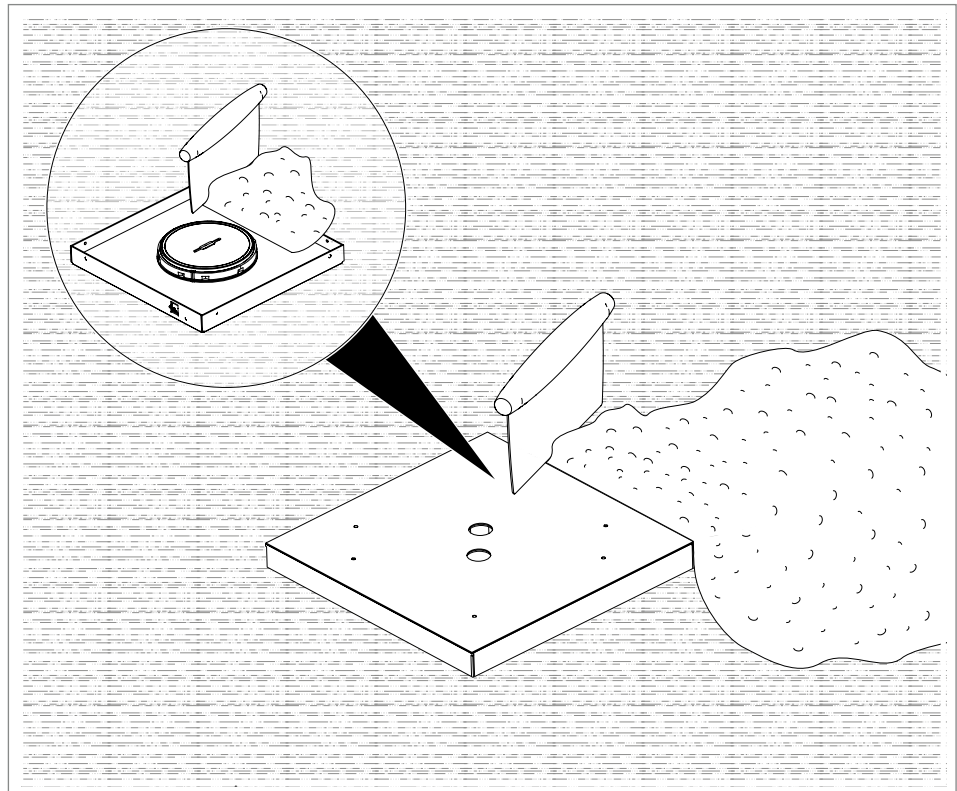

Fig. 16: Applying the Terrazzo covering

1. Coat the quartzed external sides of the cassette **4** with a reaction resin bonding course.
2. Apply the design screed/Terrazzo covering (facing formwork) to the floating support screed.
3. Pre-finish the design screed/Terrazzo covering (facing formwork) for the cassette cover **1**, polish it and stick it to the cover or apply Terrazzo mortar to the cassette cover **1** using a suitable reactive resin bonding course and polish after hardening.

Note! *Do not polish over the aluminium cover of the screed protection cover.*

4. Polish the design screed/Terrazzo covering (facing formwork).
5. Remove the screed protection cover **3** and then dispose of it.

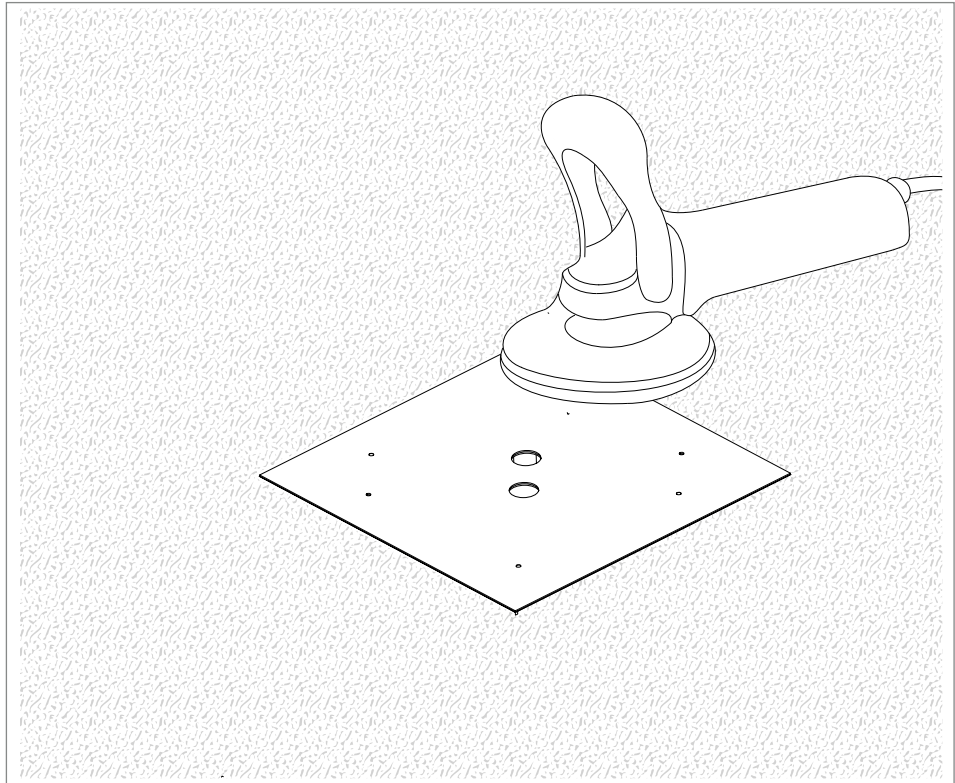

Fig. 17: Working up the Terrazzo covering

6. Using a hand polisher, work the design screed/Terrazzo covering (facing formwork) up to the cassette ④.

6.6 Final work after screed laying

The polishing of design screeds and Terrazzo coverings is carried out in multiple work steps. Depending on the type of design, the surface is only polished without any significant removal. The surface is ground coarsely or finely, until the desired particle size and shape on the surface becomes visible. In this case, the design screed/Terrazzo covering (facing formwork) is first installed approx. 3–5 mm higher than intended by the target height.

The surfaces are polished using diamond grinding machines.

Hand-held polishing machines are used for the edges of the underfloor sockets with cassette solutions. In doing so, the screed protection cover is also polished in the edge area.

During the entire polishing work, including filling, fine polishing and sealing, the screed protection covering remains in the cassette frame, protecting the components against damage and soiling.

The polishing and additional work must usually be carried out very carefully.

The cassette covers must always be worked separately to the surface working. Due to the delicate structure of the cassette covers, it is important to dismantle the cord outlet covers before work, or to cover the opening for the cord outlet/tube body. The cassette covers can be covered with a Terrazzo plate created and worked from screed mortar in

advance. Any gaps appearing between the cassette frame and the plate can be filled and worked with filler. With careful work, the gap area can barely be noticed when finished. Alternatively, the cassette cover can also be filled with facing mortar and polished after hardening. We recommend specifying the procedure using a sample, in agreement with those involved.

6.7 Inserting accessories

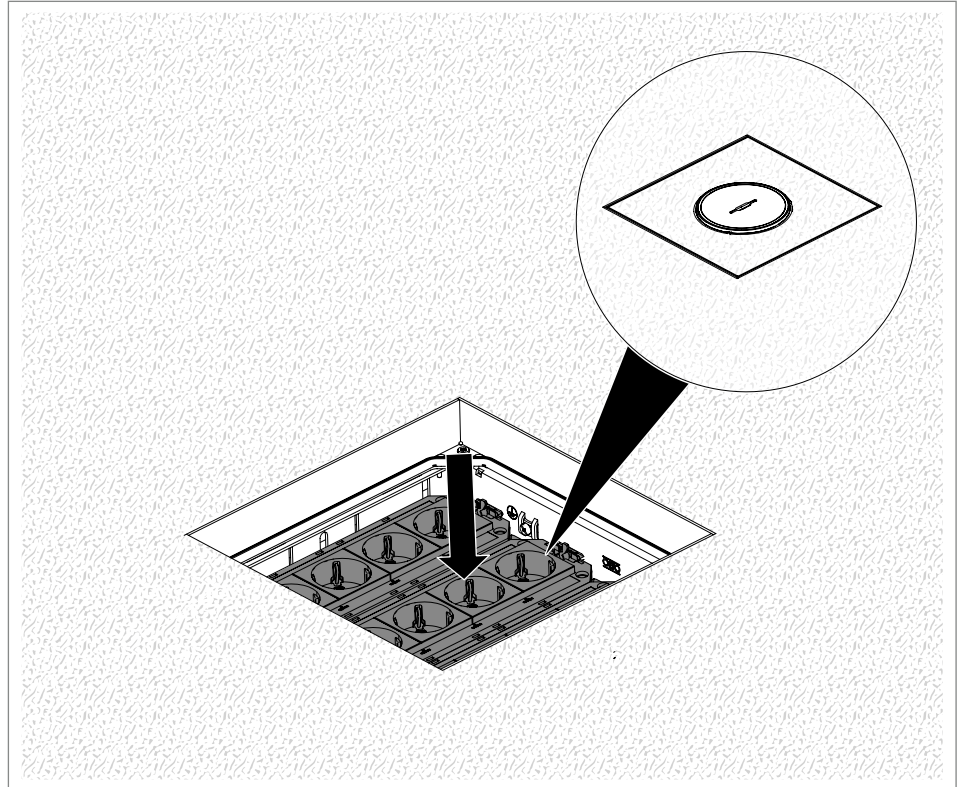

Fig. 18: Inserting accessories

Note! *If the cassette has not been decoupled (by removing the holding claws), then the outer universal supports cannot be installed.*

1. Insert the accessories and universal supports.
2. Insert the cassette cover **1**.

7 Dismantling the cassette

Destruction-free dismantling of the cassette is not possible.

8 Disposing of the cassette

Comply with the local waste disposal regulations.

- Screed protection cover: As scrap metal (aluminium and galvanised steel)
- Holding claws: As scrap metal (galvanised steel)

- Screws: As scrap metal (galvanised steel)
- Plastic parts: As plastic
- Packaging: As household waste (depending on packaging type)

9 Technical data

Nominal size 9	
System	
Minimum system installation depth	From 140 mm (UGD55) From 155 mm (UZD)
Underfloor accessory socket	UZD 250 (z. B. 7410030) UGD55 250 (z. B. 7410060) UZD 350 (z. B. 7410034) UGD55 350 (z. B. 7410062)
Dimensions	
UZD	410 x 367 x 70 mm
UGD55	410 x 367 x 55 mm
UZD 350	510 x 467 x 70 mm
UGD55 350	510 x 467 x 55 mm
Product	
Material	1.4301 steel, strip-galvanised
Adjustable height range (summary of screed and design screed thickness)	68.5-108.5 mm
Material of the cassette	Stainles steel, Brass
Dimensions of the cassette L x W	243 x 243 mm
Floor care type (according to EN 50085-2-2)	Wet, dry
Height of the ISO apron	12.5 mm

Tab. 2: Technical data

OBO Bettermann Holding GmbH & Co. KG

P.O. Box 1120
58694 Menden
GERMANY

Customer Service Germany

Tel.: +49 (0)2373 89-1700
Fax: +49 (0)2373 89-1238
E-mail: info@obo.de

www.obo-bettermann.com

Building Connections

